

SMTIR2102 INFRARED SENSOR

Typical applications

- contactless measurement of surface temperatures or Infrared radiation
- temperature measurement on moving objects
- continuous temperature control of manufacturing
- thermal alarm systems
- climate control
- medical instruments like “earguns”
- home appliances



Features

- High accuracy
- High sensitivity (7mV@100°C)
- Low resistance (70 KΩ) and therefore
- Very good signal-to-noise-ratio
- Good response time (12 ms)

Introduction

The Smartec infrared sensor SMTIR2102 is a sophisticated full silicon infrared sensor. The sensor can be used in measuring the radiation temperature without any contact. For the different radiation temperature ranges various filters are available. The sensor type SMTIR2102 contains a temperature sensor for measuring the temperature of the sensor itself. The temperature range of the sensor-element is between - 20 to 100 °C. The sensor is available in a standard TO-5 encapsulation and with a 5.5. µm. high pass filter.

Pin-out and housing (TO-5)

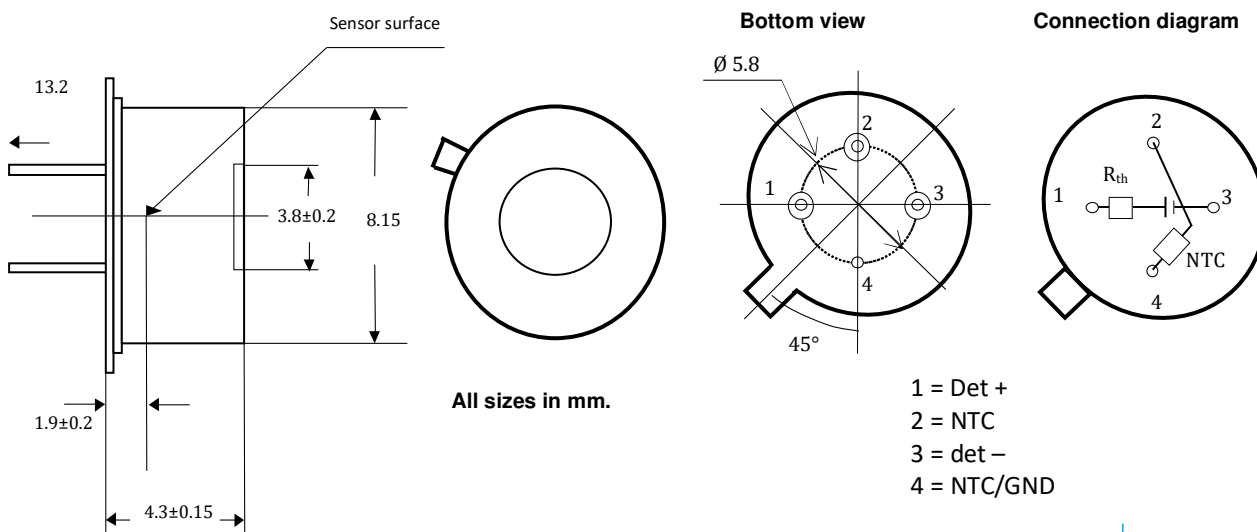

Product description.

Thermopiles are based on the Seebeck effect, which can be considered ever since a long time as standard for conventional thermocouples. The application of thin film technology allows the production of miniaturized and low cost sensor elements.

A series connection of thermo junctions deposited on a silicon substrate forms the thermopile. The hot junctions are thermally isolated from the cold junctions on the substrate by etching an extremely thin membrane. A black absorbing layer on the hot junctions transforms the incoming radiation into heat. A voltage proportional to the radiation is generated by the thermoelectric effect.

For different radiation spectra various filters are available to find the optimal solution.

Specifications

Parameter	Typical	Unit	Condition
Thermo pile			
Active area	0,64	mm ²	
Die size	3	mm ²	
Window size	3,8	mm Ø	
Field of view	88	°	@ 50% signal
Resistance of thermopile (Rth)	70±35	KΩ	@ 25 °C
TC of Rth	-0,06	%/K	
Output Voltage (OV)	7,0±2	mV	@ 25 °C, T _{obj} = 100°C, see graph
TC of OV	-0,45	%/K	
Noise equivalent voltage	45	nV/Hz ^{1/2}	rms value
Time constant	12	ms	±20%
Filter cut on	5,5	µm	±10%
NTC			
Reference thermistor	100	KΩ	T _{amb} = 25 °C
beta value of thermistor	3955	K	0 -- 50 °C
Operating temperature	-20 -- +85	°C	
Storage temperature	-40 -- +100	°C	
Package	TO-05		



PRELIMINARY

SMTIR2102

Understanding the specifications

Sensitive area.

The sensitive area is a square of 0.5 mm^2 . By using the distance between the sensor element and the glass filter and its diameter the field of view can be determined. The field of view can be changed by using special lenses. In case lenses are used the emissivity and the spectrum has to be considered.

Filter.

The sensors are standard wise equipped with a high pass filter. From the theory it is well known that each body has a radiation at a certain temperature. This radiation temperature has a frequency related to that temperature. For general use the filter used is a high pass filter with a cut-off wavelength of $5.5 \mu\text{m}$.

Filter characteristic

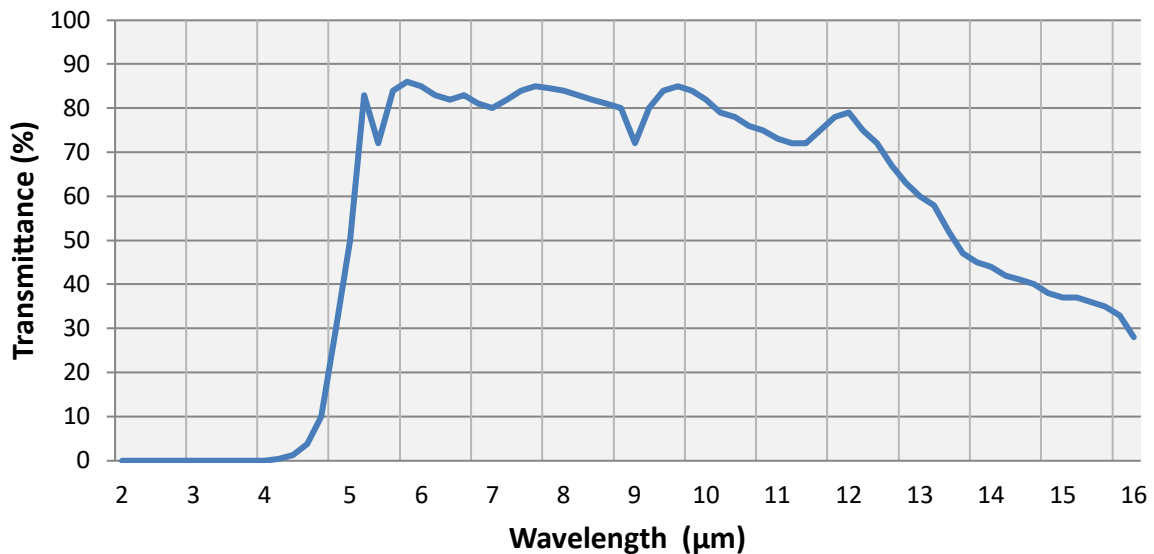

Sensor resistance.

It must be clear that this type of thermopile has a reasonable output resistance. This resistance has to be considered when designing the input amplifier to prevent off-sets, etc.



SMTIR2102**Time constant.**

The time constant is the time needed to reach an output voltage of 63 % of the final signal level. This time constant only depends on the physical construction.

Output Voltage (OV)

The below graphs give the output response as function of the temperature of a black body.

Sensor temperature = 25 °C

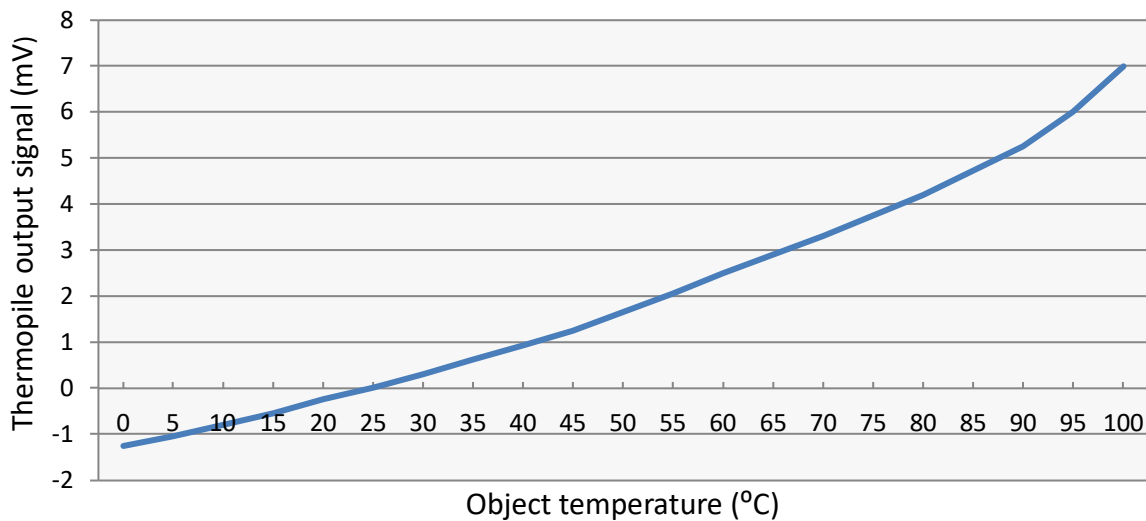
**Temperature reference resistor.**

It is well known that for application on an infrared sensor the temperature of the sensor must be considered in the calculation of the radiation temperature. The used resistor is a standard NTC resistor with a value of 100 k Ω @ 25 °C and has β value of 3811

Ordering information

SMTIR2102 Infrared sensor with NTC temperature sensor

Distributed by
MMS
 ELECTRONICS
 www.mmselectronics.co.uk

for more info:

sales@smartec-sensors.com

